



Instruction Booklet 使用說明



IONIC 2-IN-1 HAIR STYLER 負離子兩用造型器

VSI-1012PIH

沙宣負離子兩用造型器

您一定會喜歡沙宣全新護髮體驗，只需兩用造型器便能做出直髮及鬚髮效果。同時負離子護髮技術，令您的秀髮無比閃亮、順滑。

認識您的兩用造型器



操作指示

此兩用造型器適合家居使用，適用電壓為100–120伏特和220–240伏特交流電。切記只可以交流電（50–60赫茲）操作。

環球電壓

此兩用造型器會自動調校至合適輸入電壓。如需要，請在插座上轉接合適的配接插頭。
(* 包括城市額定電壓 100–120V 和 220–240V)

使用說明

第一次使用本電器時，您可能看到少許蒸氣和聞到一些異味：這是正常現象，會在下一次使用時消失。如果聽到輕微的劈啪聲，這是正常的，這是負離子發生器發出的聲音。

- 只適用於乾髮。
- 將電器插頭插入電源，使用溫度調節按鈕選擇適合的溫度。
- 由於每個人的髮質不同，建議您在第一次使用本產品時選擇 “I” 溫度設置。如必要，可以在之後的使用中逐漸提高溫度。

溫度設置	溫度	設置建議
I	180°C	直髮造型：適合纖細、漂染和/或受損的頭髮 捲髮造型：適合柔軟和/或彎曲的頭髮
II	230°C	僅可用於直髮造型，適合正常、濃密和/或不易定型的頭髮

造型建議

直髮造型

- 徹底梳順頭髮，然後將頭髮分區。
- 從底層的頭髮開始。取一縷約5厘米寬的頭髮，將其放在兩個熱的直髮板中間，然後將直髮板放在靠近髮根的位置，注意不要用手觸摸高溫電器表面。
- 用直髮板夾緊頭髮，緩緩地從髮根向髮梢滑動。
- 如必要，重複以上步驟。
- 待頭髮冷卻後再梳理。
- 使用過後，關閉溫度調節按鈕，拔下電器插頭。待兩用造型器冷卻後再收納。

鬚髮造型

- 取一縷約2–3厘米寬的頭髮，將其放在2個加熱夾板中間，然後將捲髮板放在髮根附近。



- 將兩用造型器向上轉動180°。



- 緩緩地將兩用造型器沿著頭髮從髮根滑到髮梢。



- 取下兩用造型器，用手指再扭動一下彎曲的頭髮，使其自然彎曲。



- 如必要，重複以上步驟。
- 可以使用定型噴霧，讓曲髮定型。
- 使用過後，關閉溫度調節按鈕，拔下電器插頭。待兩用造型器冷卻後再收納。

注意：

在使用本電器時，您可能會看到一些蒸氣。不要擔心，這可能是因為油脂、一些殘留的美髮產品（殘留的護髮產品、定型噴霧等）或多餘的水分從您的頭髮中蒸發造成的。

保養

您的兩用造型器無需特別保養，無需添加潤滑油。如需清潔機身，請先拔掉電源插頭並待機身降溫，然後用布塊擦拭機身外表。若有任何異常情況，讓電器冷卻並交回沙宣顧客服務中心維修。切勿自行修理電器。

為保持兩用造型器的最佳表現，請注意下列保養須知：

- 切勿讓尖銳物件接觸板面，或用粗糙物料磨擦板面。
- 切勿與強力化學品一併使用，如電髮水。
- 切勿使用強力清潔劑清潔板面；一般情況下，溫和清潔劑可輕易清除污漬及殘留的髮型用品。

小心

切勿拉扯、扭曲或過度彎曲電源軟線。切勿將電源軟線纏繞在機身上，否則容易損壞接入機身的可轉動部位，導致電源軟線破裂或短路。如發現兩用造型器損壞、停止或間歇性停止操作，請立即停用。

收存

不使用本兩用造型器時，可待機身降溫後，將其收存於安全、乾燥及遠離兒童的地方。切勿以拉扯電源軟線的方式拔出插頭；切勿將電源軟線纏繞在機身上。確保電源軟線接入機身部分垂直，其餘部分自然放置即可。

重要安全指示

當使用電器時，尤其有兒童在場，應小心及遵守以下安全指示：

使用前請細閱使用說明 電器應遠離水源

安全預防措施

警告：請小心包裝或產品上使用的膠袋，請擺放在遠離兒童的位置。請不要在嬰兒床、睡床、嬰兒車或兒童玩耍區內使用，因為膠袋的薄層有可能會堵住鼻子及口腔，阻礙呼吸。此膠袋不是玩具，敬請注意。



警告：不要在盛水的浴缸、淋浴、洗臉盆或其他器皿附近使用本器具。



- 當電器在浴室使用後，應立即拔除插頭，因為電器接近水會導致危險，即使開關已關掉。為提供額外的安全性保護，建議閣下在提供浴室電源的電路中安置不超過30毫安培(mA)的漏電斷路掣(RCD)；如有疑問，請向負責安裝的電機工程師查詢。
- 切勿把電器放入或掉進水或其它液體中。
- 如果電源軟線損壞，為了避免危險，必須由製造商、其維修部或類似部門的專業人員更換。

- 若電器曾跌落或有任何不妥，請馬上停止使用。
- 切勿將已接上電源或開啟的電器置之不理。
- 如若在使用中有任何不妥，請馬上拔去插頭。
- 請不要使用非本產品提供的任何配件。
- 每次用完后或清潔前請先拔去插頭。
- 切勿將電器發熱的部份碰到身體，尤其是眼睛、耳朵、面部和頸部。
- 在無成人監管的情況下，不建議兒童或殘疾人士獨自使用此電器。禁止兒童把此電器當作玩具把玩。
- 待電器冷卻之後才收藏。
- 為避免損壞電源軟線，收藏時切勿將電源軟線纏繞在電器上並確保其不被拉扯、扭曲或屈折。
- 使用前請先閱讀本使用說明中有關環球電壓的資料。
- 請勿配合變壓器使用。

電路說明

總電線的顏色根據其性質而定：

藍色代表中線
棕色代表火線

由於電器的總電線顏色和插頭的電路接頭顏色可能不相符，故如要拆除插頭必須依照以下重新裝配操作說明：

- 藍色的電線應和電路接頭“N”接駁。
- 棕色的電線應和電路接頭“L”接駁。
- 切勿將以上任何一條電線駁在電路接頭的地線“E”或⊕插頭上。

此電器使用十三安培電插頭時，請採用三安培的保險絲。若使用其他電插頭，請採用三安培保險絲。

兩年保養期限

在您購買日期起兩年內，並在正常情況下，如產品的品質或零件有任何不妥之處，沙宣顧客服務中心將會為您免費提供維修或換貨服務。如需獲得此保用服務，只需保留正本收據，倘若產品於保養期內有任何問題，可蒞臨您所在地區的顧客服務中心處理。注意：是項保養不包括一切因錯誤使用、不依指示處理產品及意外損毀、遺失零件及經自行改造的產品。

保用期之後

請致電使用說明中所列出的您所在地區的沙宣顧客服務中心，諮詢維修服務詳情，或是電郵至email_asia@conair.com，附上您的名字，電話號碼和電郵地址，還有產品不妥善之詳情。

如欲了解更多，請登入



通過此二維碼也可獲取電子說明書

CONTINENTAL CONAIR LIMITED CHINA CREATIVE DEPARTMENT

Date	04/7/2021
Customer	VS-HK
Model No.	VSI-1012PIH
Description	IB
Job No.	
Reference No.	IB-18/061B
Revision No.	0
Color	1C+1C(Black)
Open Size	552mm(W) X 214mm(H)
Folded Size	92mm(W) X 214mm(H)
Material	80gsm Artpaper
Prepared by	Betty Bai
Approved by	Ken Xiong
Vendor	MILLPLAN
Supplier	

折疊方法
Folding method:
12 pages (6 x 2)

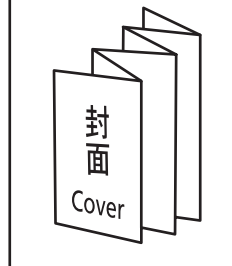

VS SASSOON SERVICE CENTRE
Manufacturer: Continental Conair Limited
Address: 35/F., Standard Chartered Tower, Millennium City,
388 Kwun Tong Road, Kwun Tong, Kowloon, Hong Kong.
Tel: (852) 2751 4604

沙宣顧客服務中心
製造商：美康雅有限公司
地址：香港九龍觀塘觀塘道388號創紀之城渣打中心35樓
電話：(852) 2751 4604

www.toolsforsassoon.com

DISTRIBUTED BY:
經銷商:

Philippines 菲律賓
Ruslan Marketing Corporation
3rd Floor, 403 Midland Building,
Senator Gil Puyat Ave., Makati City, Philippines
Tel: (632) 890 9703 Fax: (632) 890 4838

Malaysia 馬來西亞
Innovest Marketing Sdn. Bhd.
Lot 2208, Jalan Kusta, Kampung Jaya Industrial Area,
47000 Sungai Buloh, Selangor D.E., Malaysia
Tel: 603 6141 3598

Singapore 新加坡
Massmark International Pte Ltd
80 Genting Lane #08-01/05
(*Drive in through 35 Tannery Road)
Ruby Industrial Complex, Genting Block
Singapore 349565
Tel: 65-6747 1102 Fax: 65-6747 8997

Indonesia 印尼
PT. Autoaccindo Jaya
JL.Cideng Barat No.7,
Jakarta 10140, Indonesia
Phone: + 6221 6332730
Fax: + 6221 6322886

Certain trademarks used under license from The Procter & Gamble Company or its affiliates.
維達沙宣及其有關標誌乃實業有限公司擁有，授權予美商美康雅公司及其關係企業使用。

VSI-1012PIH

IB-18/061B

VS IONIC 2-IN-1 HAIR STYLER

You will be pleased by selecting straight or curl hair styling in one device. It also features ionic technology to give your hair incomparable shine and less frizzy.

GET TO KNOW YOUR IONIC 2-IN-1 HAIR STYLER

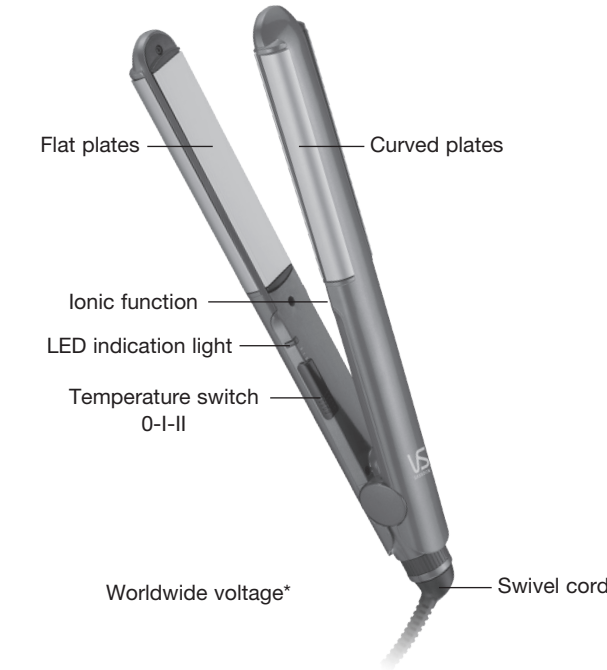

OPERATING INSTRUCTIONS

This hair styler is intended for household use. This unit is designed to operate at 100–120 volts and 220–240 volts AC. Use on Alternating Current (50-60 hertz) only.

WORLDWIDE VOLTAGE

This hair styler will automatically adjust to the proper voltage. Use an adapter plug with correct configuration, prior to use in outlet. (* include cities with rated voltage 100-120V and 220-240V)

INSTRUCTIONS FOR USE

The first time you use the unit, you may notice a little steam and a particular odor; this is common and will disappear the next time you use it. You will also notice that the unit sputters slightly, this sound is normal for a high output ion generator.

- Use on dry hair.
- Plug in the appliance, switch on and select the desired temperature using temperature switch.
- Since every hair type is unique, we recommend you use the first setting "I" the first time you use it. Progressively increase the temperature, if necessary, during the following uses.

Setting	Temperature	Suggestion
I	180°C	Straightening: thin, bleached and/or sensitized hair Curling: soft or tight curls
II	230°C	Straightening: normal, thick and/or wavy hair

STRAIGHTENING YOUR HAIR

- Thoroughly brush hair and section.
- Start with the underneath sections of hair. Take a section of about 5 cm width and place it between the 2 hot plates with the flat plates to straighten positioned close to the roots, being careful to avoid touching the hot surface of the appliance with your hand.
- Hold the hair firmly with the flat plates to straighten and slide slowly along from the roots to the tips.
- Repeat again if necessary.
- Let the hair cool down before you comb it.
- After use, switch off and unplug the hair styler. Allow to cool before storing away.

CURLING YOUR HAIR

- Take up a section about 2 to 3 cm wide and place it between the 2 heating plates, use curved plates to curl near the roots of your hair.



- Turn the hair styler 180° upwards.



- Slowly glide the hair styler over the length of the section, from the roots to the tips.



- Remove the hair styler and use your fingers to twist the section

again so that it takes its natural position.



- Repeat if necessary.
- You may wish to set the curls using a light misting of hairspray.
- After use, switch off and unplug the hair styler. Allow to cool before storing away.

Note! When you are using the appliance, you might see some steam. Do not be concerned, this could be because of evaporation of the sebum, some residual hair products (leave-in hair care, hairspray, etc.) or excess water that is evaporating from your hair.

MAINTENANCE

Your 2-in-1 hair styler is virtually maintenance-free. No lubrication is needed. Keep all openings clear of dirt and dust. If cleaning becomes necessary, disconnect the unit from the power source, allow to cool, and wipe exterior with a cloth. If any abnormal condition occurs, unplug the unit, allow it to cool, and return it for repair to an authorized service representative only. No repairs should be attempted by the consumer.

However, in order to keep the best performance from your 2-in-1 hair styler all the time, please note the following care instructions.

- Do not scratch the surface of the plates with sharp objects or wipe with coarse material.
- Do not use this hair styler with strong chemicals, like perm lotions.
- Do not clean the plates with strong cleaning agents. In most cases, mild detergent will be able to remove any stains or traces of styling products left on the plates easily.

CAUTION

NEVER allow the power supply cord to be pulled, twisted, or severely bent. Never wrap the cord tightly around the appliance. Damage will occur at the high flex point of entry into the appliance, causing it to rupture and short circuit. Inspect the cord frequently for damage. Stop use immediately if damage is visible or if unit stops or operates intermittently.

STORAGE

When not in use, your 2-in-1 hair styler is easy to store. Allow appliance to cool, then store out of reach of children in a safe, dry location. Do not jerk or strain cord at plug connections. Do not wrap the line cord around the appliance. Allow the cord to hang or lie loose and straight at the point of entry into the appliance.

IMPORTANT SAFETY INSTRUCTIONS

When using electrical appliances, especially when children are present, basic safety precautions should always be followed, including the following:

READ ALL INSTRUCTIONS BEFORE USING KEEP AWAY FROM WATER

SAFETY PRECAUTIONS

WARNING: The polyethylene bags over the product or its packaging may be dangerous. Keep these bags out of the reach of babies and children. Never use them in cribs, children's beds, pushchairs or playpens. The thin film may cling to the nose and mouth and prevent breathing. A bag is not a toy.



WARNING: Do not use this appliance near bathtubs, showers, basins or other vessels containing water.

1. If you are using the unit in a bathroom, unplug it after you have finished using it. Using the unit close to a source of water can, in fact, be dangerous, even if the unit is switched off. To ensure additional protection, have installed in your bathroom a residual current device (RCD) with a nominal trip current no higher than 30 mA. Ask your electrical fitter for advice.
2. Never immerse the unit in water or any other liquid.
3. If the supply cord is damaged, it must be replaced by the manufacturer, its service agent or similarly qualified persons in order to avoid a hazard.
4. Do not use the unit if it has fallen or if it appears to be damaged.
5. Do not leave the unit unattended when it is plugged in or switched on.
6. Unplug the unit immediately if you have problems when using it.
7. Do not use any accessories other than those recommended by manufacturer.
8. Unplug the unit after each use and before cleaning it.
9. Avoid any contact between the unit's hot surfaces and your skin, in particular, your ears, eyes, face and neck.
10. This unit is not intended for use by people (including children) with reduced physical, sensory or mental capabilities, or by persons who lack experience or knowledge, unless they are supervised or have been given instructions beforehand on the use of the unit by a person responsible for their safety. Children should be supervised to make sure they do not treat the unit like a toy.
11. Allow the unit to cool before storing.
12. To prevent damage to the cord, do not wrap it around the unit and ensure it is stored without twisting or folding it.
13. Before plugging in, read the information about worldwide voltage contained in the operating instructions section of this manual.
14. Do not use with a voltage converter.

WIRING INSTRUCTIONS

The wires in the mains lead are coloured in accordance with the following code:

BLUE = NEUTRAL
BROWN = LIVE

As the colours of the wire in the mains lead of this appliance may not correspond with the colour markings identifying the terminals on your plug proceed as follows:

- The wire which is coloured BLUE must be connected to the terminal which is marked with the letter 'N'.
- The wire which is coloured BROWN must be connected to the terminal which is marked with the letter 'L'.
- Neither the BLUE nor BROWN wires should be connected to the terminal which is marked with the letter 'E' or the ⊕ symbol.

With this appliance, if a 13 amp plug is used a 3 amp fuse should be fitted. If any other type of plug is used a 3 amp fuse must be fitted either in the plug or at the distribution board.

LIMITED TWO YEAR WARRANTY

This styler can be repaired or replaced free of charge for 2 years from the date of purchase if the styler is defective in workmanship or materials. This warranty is no longer valid in case of alteration or repair by any unauthorised persons. To obtain service under this warranty, please keep the original purchase receipt for warranty service, and you can bring the styler to our customer service center for repair during the warranty period.

OUT OF GUARANTEE

Call VS Sassoon Service Centre in your region as listed in this Instruction Booklet for details of repair service. Or email to us at email_asia@conair.com with your name, contact telephone number and email address and details of the fault.

For more information, please visit



You can also obtain digital instruction manual by QR code.